



## Rx Only

### **INTERCEPT® Blood System for Platelets - Package Insert – Dual Storage (DS) Processing Set**

#### **DESCRIPTION**

The INTERCEPT® Blood System for Platelets is intended for the ex vivo treatment and storage of platelet components. The system is used to inactivate a broad range of pathogens, including viruses<sup>1-10</sup>, bacteria, and protozoan parasites<sup>11-15</sup>, thus reducing the risk of transfusion-transmitted infections. Contaminating donor leukocytes are also inactivated by the INTERCEPT treatment, reducing the risk of transfusion-associated graft versus host disease (TA-GVHD).<sup>16-20</sup>

The INTERCEPT Blood System for platelets is a Class IV medical device consisting of single-use processing sets containing amotosalen solution (INTERCEPT Processing Sets) and an illumination device (INTERCEPT Illuminator INT100, software version 6.1), which provides a controlled dose of ultraviolet A (UVA) light for each treatment. Platelet components treated with the INTERCEPT Blood System are referred to as INTERCEPT Platelets.

The INTERCEPT Blood System for platelets is available in several processing set configurations. This package insert describes information specific for the Dual Storage (DS) processing set.

The DS set includes two final platelet storage containers and is used for the treatment and storage of double dose platelet concentrates. The Instructions for Use section describes the platelet unit specifications required for treatment using this processing set. The key components of the DS set are as follows:

- Amotosalen container with 17.5 mL of 3 mM amotosalen solution in 0.924% saline
- Illumination container for treatment in INTERCEPT Illuminator
- Compound Adsorption Device (CAD) for removal of residual amotosalen and free photoproducts
- Platelet storage containers

The INTERCEPT Illuminator delivers a controlled amount of UVA light (wavelength 320 to 400 nm) to the illumination container during each treatment cycle. The machine has the capability of illuminating 1 or 2 INTERCEPT processing sets per treatment cycle. Each illumination container rests on a UVA transparent tray that undergoes horizontal agitation during the illumination process. UVA illumination in each chamber is provided by 2 opposing banks of fluorescent lamps mounted above and below the illumination tray, and is monitored by independent photodiode systems which integrate the UVA dose. The INTERCEPT Illuminator delivers a 3 Joules/cm<sup>2</sup> (J/cm<sup>2</sup>) UVA treatment within approximately 3 to 4 minutes. Upon completion of the illumination step, the platelets are transferred to the bag containing the CAD and agitated for 6-24 hours, depending on the platelet suspension medium, at 22°C ± 2°C. At the completion of the CAD incubation, the platelets are transferred by gravity flow to the storage container and are ready for transfusion.

## PRINCIPLE OF OPERATION

The INTERCEPT treatment process utilizes the synthetic psoralen known as amotosalen (also referred to as S-59; structure shown in **Figure 1** below). Psoralens are a class of planar, aromatic molecules that can bind reversibly to nucleic acids by intercalation. Upon illumination with long wavelength UVA light, intercalated psoralens form monoadducts and interstrand crosslinks with RNA and DNA.<sup>21</sup> The result is permanent, irreparable adducts in DNA and RNA, which prevent replication of pathogens and leukocytes.<sup>21</sup> The intercalation, illumination and crosslinking mechanism of action is shown in **Figure 2**.

**Figure 1 Amotosalen: C<sub>16</sub>H<sub>19</sub>NO<sub>4</sub>**

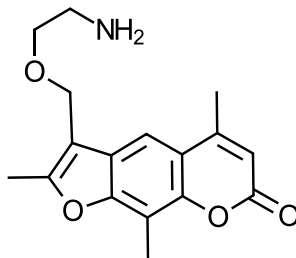

**Figure 2 Amotosalen Mechanism of Action**

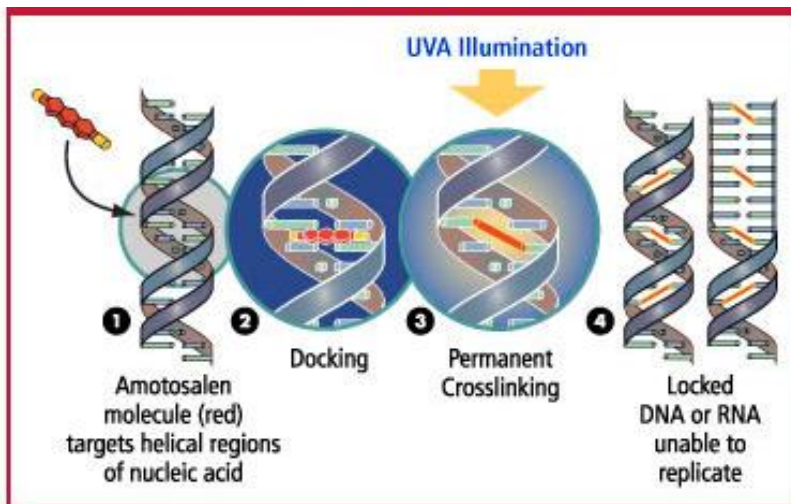

## INDICATIONS AND USAGE

The INTERCEPT Blood System for platelets is intended to be used for the ex vivo preparation of pathogen-reduced, whole blood derived buffy coat platelet or apheresis platelet components in order to reduce the risk of transfusion-transmitted infection (TTI).

## CONTRAINDICATIONS

- Contraindicated for preparation of platelet components intended for patients with a history of hypersensitivity reaction to amotosalen or other psoralens.
- Contraindicated for preparation of platelet components intended for neonatal patients treated with phototherapy devices that emit a peak energy wavelength less than 425 nm, or have a lower bound of the emission bandwidth <375 nm, due to the potential for erythema resulting from interaction between ultraviolet light and amotosalen.

## WARNINGS

Treatment with INTERCEPT Blood System does not replace applicable standards for processing in open and closed systems. If there is a leak in the set during processing, the platelet product must be discarded.

Amotosalen in contact with skin may result in photosensitization in the presence of ultraviolet light. If skin exposure occurs, flush exposed skin with water.

The sterile connecting device (SCD) and tube sealer should be used according to manufacturer's instructions for use.

While laboratory studies of amotosalen processing with UVA light have shown a reduction in levels of certain viruses, bacteria, and parasites, there is no pathogen inactivation process that has been shown to eliminate all pathogens.

Di(2-ethylhexyl) phthalate (DEHP) is known to be released from polyvinyl chloride (PVC) medical devices; increased leaching can occur with extended storage or increased surface area contact. The INTERCEPT processing sets only have tubing components, container ports and an in-line filter that contain PVC; all containers and other parts are PVC-free. During use of this processing set, blood components are in contact with PVC for a brief period of time (approx. <15 minutes). Based on limited surface area contact and minimal contact time, DEHP levels in blood components after use of the processing set are estimated to be well below those resulting from other medical applications containing PVC tubing (e.g., hemodialysis, intravenous fluid administration, extracorporeal membrane oxygenation and cardiopulmonary bypass procedures). The risks associated with DEHP released to the blood components must be weighed against the benefits of therapeutic transfusion and inactivation of harmful viruses, bacteria and other pathogens.

Pulmonary events: Acute Respiratory Distress Syndrome (ARDS)

INTERCEPT processed platelets may cause the following adverse reaction: *Acute Respiratory Distress Syndrome (ARDS)*

An increased incidence of ARDS was reported in a randomized trial for recipients of INTERCEPT processed platelets, 5/318 (1.6%), compared to recipients of conventional platelet components (0/327). Monitor patients for signs and symptoms of ARDS.<sup>22,23</sup>

## **PRECAUTIONS**

The INTERCEPT processing sets are intended for single-use. Do not reuse sets or components of sets.

Do not use if: tamper-evident package has been opened; signs of deterioration are visible; fluid path closures are loose or not intact; cannulae are broken; or there is no fluid in the amotosalen solution container.

All the following conditions must be met for pathogen inactivation:

- Platelet collection should be in accordance with blood bank practice.
- Platelets mixed with amotosalen must be exposed to UVA light using the INTERCEPT Illuminator. No other source of UVA light may be used. Please refer to the Operator's Manual for the INTERCEPT Illuminator.
- Platelets must be incubated with the CAD after illumination and prior to use. Refer to the Instructions for Use section for the appropriate minimum and maximum CAD incubation times.

The INTERCEPT Blood System can accommodate a range of platelet collection and processing technologies. However, regardless of the method of collection or processing, blood establishments need to adjust their practices to conform to defined product guard bands for input volume, treatment window times, and other key processing parameters.

Treat all blood products as though they contain an infectious agent. Follow institutional guidelines regarding the handling of infectious agents. Dispose of all materials used in the procedure as biohazardous waste.

## **ADVERSE EVENTS**

Because clinical trials are conducted under widely varying conditions, adverse reaction rates observed in the clinical trials of a product cannot be directly compared to rates in the clinical trials of another product and may not reflect the rates observed in clinical practice.

As anticipated, a large number of adverse events (AEs) were reported in the clinical studies in patients with severe platelet-dependent thrombocytopenia, including patients treated for malignancy and patients undergoing hematopoietic stem cell transplantation (HSCT). Most events were considered to be related to the primary disease treatment and/or the underlying disease and were not reported as related to the use of study platelets.

In the Phase 3/3B randomized controlled blinded trials enrolling patients repeatedly transfused with INTERCEPT Platelets prepared from single donor apheresis or pooled donor buffy coat products and stored for up to 5 days, adverse events were classified as possibly, probably, or related to the exposure to INTERCEPT Platelets.<sup>24-26</sup> Those related adverse events observed in  $\geq 5\%$  of patients included transfusion reactions (13%), blood alkaline phosphatase not otherwise specified (NOS) increased (5%), blood urea increased (5%) and petechiae (7%). Adverse reactions (defined as possibly or probably related to study transfusion) that occurred in  $\geq 5$  (1.25%) patients treated with INTERCEPT or conventional (control) platelets in these randomized clinical trials are summarized in **Table 1**.

**Table 1 Related Adverse Events Occurring in  $\geq 5$  (1.25%) Patients Treated with INTERCEPT or Conventional (Control) Platelets in Randomized Phase 3/3B Clinical Trials**

Event	INTERCEPT (n=392)	Control (n=399)	Event	INTERCEPT (n=392)	Control (n=399)
Any AE	103 (26%)	112 (28%)	Blood Lactate Dehydrogenase Increased	6 (2%)	5 (1%)
Febrile Neutropenia	5 (1%)	1 (<1%)	Blood Magnesium Decreased	15 (4%)	5 (2%)
Thrombocytopenia	4 (1%)	7 (2%)	Blood Urea Increased	18 (5%)	11 (3%)
Transfusion Reaction	51 (13%)	65 (16%)	Faecal Occult Blood Positive	15 (4%)	13 (3%)
Haematemesis	7 (2%)	8 (2%)	Weight Increased	7 (2%)	7 (2%)
Mouth Haemorrhage	8 (2%)	9 (2%)	Hypermagnesaemia	6 (2%)	4 (1%)
Injection Site Erythema	7 (2%)	8 (2%)	Hyperphosphataemia	12 (3%)	9 (2%)
Oedema Lower Limb	9 (2%)	6 (2%)	Hypocalcaemia	13 (3%)	7 (2%)
Pyrexia	11 (3%)	8 (2%)	Hypokalaemia	16 (4%)	11 (3%)
Rigors	15 (4%)	12 (3%)	Hyponatraemia	12 (3%)	6 (2%)
Hyperbilirubinaemia	6 (2%)	8 (2%)	Hypophosphataemia	10 (3%)	9 (2%)
Hypoproteinaemia	12 (3%)	13 (3%)	Headache NOS	1 (<1%)	6 (2%)
Jaundice NOS	7 (2%)	7 (2%)	Haematuria	17 (4%)	13 (3%)
Activated Partial Thromboplastin Time Prolonged	6 (2%)	3 (1%)	Dyspnoea NOS	6 (2%)	3 (1%)
Alanine Aminotransferase Increased	11 (3%)	9 (2%)	Epistaxis	14 (4%)	18 (5%)
Aspartate Aminotransferase Increased	15 (4%)	12 (3%)	Haemoptysis	7 (2%)	6 (2%)
Bilirubin Conjugated Increased	6 (2%)	5 (1%)	Hypoxia	6 (2%)	3 (1%)
Blood Alkaline Phosphatase NOS Increased	18 (5%)	13 (3%)	Pleural Effusion	5 (1%)	3 (1%)
Blood Bilirubin Increased	5 (1%)	5 (1%)	Contusion	16 (4%)	20 (5%)
Blood Carbon Dioxide Decreased	6 (2%)	5 (1%)	Dermatitis NOS	14 (4%)	9 (2%)
Blood Chloride Increased	4 (1%)	6 (2%)	Erythema Not Elsewhere Classified (NEC)	5 (1%)	8 (2%)
Blood Creatinine Increased	8 (2%)	6 (2%)	Petechiae	29 (7%)	17 (4%)
			Pruritus NOS	8 (2%)	9 (2%)
			Urticaria NOS	6 (2%)	4 (1%)
			Catheter Site Haemorrhage	7 (2%)	6 (2%)
			Refractoriness To Platelet Transfusion	15 (4%)	6 (2%)

*Hemorrhage:* Hemorrhagic AEs occurred in all studies, and generally consisted of mild mucosal-cutaneous bleeding. Clinically severe hemorrhagic AEs were observed at equivalent frequencies following administration of INTERCEPT or conventional platelets across the controlled clinical studies.

*Clinical refractoriness to platelet transfusion:* Clinical refractoriness to study platelet transfusions, defined as 2 consecutive study platelet transfusions with the 1-hour CCI  $< 5 \times 10^3$ , was monitored in the prospective phase 3/3B studies. In one study, there was a significantly higher rate of clinical refractoriness to platelet transfusions based on this definition [21.4% (68/318) with INTERCEPT Platelets compared to 7.0% (23/327) with conventional platelets]. Clinical refractoriness was transient and the frequency of persistent refractoriness was not increased with exposure to INTERCEPT Platelets.<sup>25</sup> There was no evidence of higher rates of immunologic refractoriness associated with INTERCEPT Platelets, and the higher rates seen in some instances were attributed to lower average platelet doses in INTERCEPT Platelets compared to reference platelet components, with resultant lower post-transfusion count increments. Persistent clinical refractoriness has not been reported in post-marketing studies.<sup>58,59</sup>

### **Immunogenicity**

2340 post-baseline plasma samples from a total of 412 subjects who received INTERCEPT Platelet transfusions in the prospective clinical studies were tested for the presence of antibodies to amotosalen or amotosalen-associated neoantigens. Four samples from two patients who received INTERCEPT Platelets prepared from buffy coat platelets were initially reactive, but other samples from these subjects were inconsistently reactive above the threshold, thus the reactivity was not considered to represent an immune response to amotosalen or amotosalen-associated neoantigens.<sup>27</sup>

## **NONCLINICAL TOXICOLOGY**

Nonclinical studies have been conducted to evaluate the potential toxicity of exposure to amotosalen. There was no indication of a toxicological risk in animal experiments using INTERCEPT Platelets. In intravenous 28-day toxicity studies in rats and dogs exposed to amotosalen, the no observed adverse effect levels were at least 75,000- and 25,000-fold, respectively, the clinical exposure from transfusion of a platelet component.<sup>28</sup>

Amotosalen was rapidly eliminated in mice and rats with an initial plasma  $t_{1/2}$  of less than 1 hour. The primary route of excretion of amotosalen and its photoproducts was fecal. There was no evidence of amotosalen accumulation after repeated exposures over periods as long as 13 weeks.

In preliminary single dose studies, transient clinical effects were seen at very high doses of amotosalen (more than 150,000 times in rat and 30,000 times in dog the daily human exposure from a single platelet component) but no target organ toxicity was observed. In 7 day studies (rat and dog) and 14 day studies (rats), there was no evidence of any systemic toxicity following exposure to high doses of amotosalen (more than 75,000 times in rat and 30,000 times in dog the daily human exposure from a single platelet component).<sup>28</sup>

In fertility studies of embryo-fetal or peri-postnatal development in rats and rabbits as well as in one study with neonatal rats, there was no evidence of reproductive or developmental toxicity of amotosalen.<sup>29</sup>

There was no *in vivo* evidence of genotoxicity or carcinogenicity of amotosalen, including a study using the validated p53 knock-out mouse model. In the presence of mammalian hepatic metabolic activation, no evidence of *in vitro* mutagenicity of amotosalen was observed.<sup>30</sup>

## CLINICAL STUDIES

The safety and effectiveness of INTERCEPT Platelets were investigated in 11 controlled clinical studies and 2 single arm observational studies.<sup>24-26,31-43</sup> A total of 1267 study subjects received INTERCEPT Platelets in the clinical studies; only the pivotal studies are presented.

### **INTERCEPT Platelets prepared from apheresis collections stored up to 5 days**

- The SPRINT Trial was a randomized, controlled, double blind, parallel-group study to compare the therapeutic efficacy and safety of INTERCEPT apheresis platelet components to conventional apheresis platelet components using a non-inferiority design.<sup>25</sup> The population selected for the study included patients with severe thrombocytopenia secondary to a spectrum of hematologic and non-hematologic malignancies, as well as other hematologic conditions associated with severe thrombocytopenia, who required platelet transfusion for prevention and/or treatment of active bleeding. The primary endpoint was the proportion of patients with Grade 2 bleeding during a period of platelet transfusion support up to 28 days. A total of 645 patients (318 Test, 327 Reference) were transfused and received a total of 4719 platelet transfusions (2678 Test, 2041 Reference). There were 186/318 (58.5%) patients in the Test group and 188/327 (57.5%) patients in the Reference group with Grade 2 bleeding. The primary efficacy endpoint of this study was met and non-inferiority of INTERCEPT Platelets confirmed using a non-inferiority margin of 12.5%. However, differences in the mean number of transfusions, average interval between transfusions, rates of refractoriness, mean days with Grade 2 bleeding and mean count increment and corrected count increment at 1 and 24 hours were all statistically significantly different favoring the control group. The observations of reduced count increments, more platelet concentrate transfusions, and shorter transfusion intervals in recipients of INTERCEPT Platelets may have been partly attributable to an increased frequency of lower platelet doses in INTERCEPT Platelets. The targeted platelet transfusion dose was  $3.7 \times 10^{11}$ . Sixty percent (60%) of the subjects in the INTERCEPT Platelet group received at least one platelet dose of less than  $3 \times 10^{11}$  compared to 36% in the control group. Additionally, subjects in the INTERCEPT Platelet group received off-protocol transfusions (32% vs. 15%) more often than the control group because of protocol violations.

There were no differences between treatment groups in the frequencies of Grade 3 and Grade 4 adverse events, serious adverse events, or mortality. Statistically significant differences for increased incidence of four adverse events of Grade 3 and Grade 4 severity were observed among recipients of INTERCEPT Platelets. These included: pneumonitis not otherwise specified (5 versus 0); ARDS (5 versus 0); hypocalcemia (21 versus 8); and syncope (6 versus 0). A subsequent blinded, retrospective analysis of patients with clinically significant pulmonary adverse events ( $n = 148$ ) demonstrated no significant increase in incidence of acute lung injury (ALI), including ARDS.<sup>23</sup> However a trend of increased ARDS in the patients receiving INTERCEPT Platelets remained. The causality of these events remains uncertain and an increased risk of ARDS with the INTERCEPT Platelets cannot be ruled out.<sup>22,23,36</sup>

- A randomized, double-blind, controlled, parallel-group trial was conducted to evaluate the therapeutic efficacy and safety of apheresis INTERCEPT Platelets prepared with the commercial INTERCEPT system compared to conventional apheresis platelet concentrates.<sup>26</sup> The study was designed as a difference study to characterize any potential differences between INTERCEPT Platelets and conventional apheresis platelet concentrates. The population selected for the study were patients receiving platelet transfusions for thrombocytopenia due to malignancy or myelosuppressive therapy for malignancy. The primary endpoint was the 1-hour platelet count increment. A total of 43 patients (22 Test, 21 Reference) were enrolled at 3 study centers, and a total of 218 platelet components were transfused (103 Test and 115

Reference). The 1-hour post transfusion platelet count increment was lower, on average by  $7.2 \times 10^{11}$  platelets for INTERCEPT Platelets compared to conventional apheresis platelet concentrates based on a longitudinal regression analysis model.

### **INTERCEPT Platelets from pooled whole blood derived buffy coat concentrates stored up to 5 days**

- The euroSPRITE trial was a randomized, controlled, double blind, parallel-group trial designed to evaluate the therapeutic efficacy and safety of INTERCEPT Platelets in comparison to conventional platelets prepared from whole blood derived buffy coat platelet concentrates.<sup>24</sup> The study was designed as a difference study to characterize any potential differences between INTERCEPT Platelets (Test) and untreated (Reference) buffy coat platelet concentrates. Hematology-oncology patients were enrolled to receive platelet transfusion support up to 56 days. The primary endpoints were the 1-hour platelet count increment. A total of 103 patients were included (52 Test, 51 Reference) and received a total of 676 platelet transfusions (390 for Test group versus 286 for Reference group). The mean per patient 1-hour CI for the Test group ( $27 \times 10^9/L$ ) was statistically significantly lower than the mean 1-hour CI for the Reference group ( $36 \times 10^9/L$ ; mean difference (95% CI) = 8.34 (1.23 to 15.45); p-value=0.02).

Statistically significant differences in the incidence of the following adverse events were observed: sepsis NOS (Not Otherwise Specified) (6 for Test group versus 0 for Reference group), blood creatinine increase (13 for the Test group versus 5 for Reference group), and phlebitis NOS (0 for Test group versus 5 for Reference group).

### **Single transfusions of INTERCEPT Platelets stored up to 7-days**

This group includes data from two studies using random donor buffy coat or apheresis platelets.

- A randomized, double-blind, single-center, two-treatment, two-period cross-over, non-inferiority pilot study was conducted to compare INTERCEPT Platelets with conventional platelets prepared from pooled random-donor buffy coat platelet concentrates with 7 day storage prior to transfusion.<sup>37</sup> The study was performed in a population of thrombocytopenic patients from a hematology-oncology clinic, and each subject received two transfusions: a single transfusion of INTERCEPT Platelets and a single transfusion of conventional platelets stored for 7 days. The primary endpoint was the 1-hour (10 to 90 min) CCI after 7-day-old platelet transfusion, and the primary efficacy analysis was performed in 20 patients: 9 patients randomized to the Sequence I-R (INTERCEPT platelets followed by Reference platelets) and 11 patients randomized to Sequence R-I. The non-inferiority of INTERCEPT platelets relative to conventional platelets could not be demonstrated for the 1-hour post-transfusion CCI.
- The TESSI study was a randomized, controlled, double-blinded, non-inferiority study designed to compare the safety and efficacy of INTERCEPT Platelets stored for 6-7 days with conventional platelets of a similar age.<sup>38</sup> Patients were recruited from the hematology-oncology departments of the participating clinical study centers, and were thrombocytopenic or expected to develop thrombocytopenia requiring platelet transfusion within 30 days of randomization. The primary endpoint was the 1-hour CCI. A total of 211 patients were randomized and received one study platelet transfusion (105 Test, 106 Reference) of platelets stored >5 days (80% of platelet concentrates were stored for 7 days). Non-inferiority of 1-hour CCI for INTERCEPT Platelets relative to conventional platelets was not demonstrated based on the full analysis set (FAS) that included all randomized patients who received the study treatment (INTERCEPT or conventional platelets).



## **Observational Studies with INTERCEPT Platelets**

This group includes data from two studies at two sites, one of which used platelet concentrates from “double-dose” apheresis collections and one of which prepared platelets from either apheresis or whole blood derived buffy coat platelet concentrates.

### **INTERCEPT Platelets prepared from apheresis and buffy coat platelets**

- This was a single-arm, open label study of 560 INTERCEPT Platelet transfusions in 51 patients with malignant hematology disorders, including HSCT.<sup>39</sup> The study was designed to monitor the safety and efficacy of INTERCEPT Platelets transfused on a routine basis in adult patients. The primary endpoint was the frequency of acute transfusion reactions. Platelet concentrates were prepared from either apheresis collections or whole blood derived buffy coat platelets, treated with INTERCEPT in place of gamma irradiation, and stored up to 5 days prior to transfusion. The frequency of acute transfusion reactions was 1.6% (9/553). This study was small in size and uncontrolled therefore the rate of acute transfusion reactions cannot be compared with that for conventional platelets.

### **INTERCEPT Platelets prepared from double-dose apheresis platelet collections**

- This study was designed as a single-arm, open observational label study of 551 INTERCEPT Platelet transfusions in 46 hematology patients with malignant disorders, including HSCT, to monitor the safety and efficacy of INTERCEPT Platelets transfused on a routine basis in a Swiss Red Cross blood center.<sup>40</sup> The primary endpoint was the frequency of acute transfusion reactions. INTERCEPT Platelets were prepared from apheresis “double unit” collections ( $5-6 \times 10^{11}$ ) without gamma irradiation and stored up to 5 days. The frequency of acute transfusion reactions was 2% (12/551). This study was small in size and uncontrolled therefore the rate of acute transfusion reactions cannot be compared with that for conventional platelets.

## **Post-Marketing Studies**

Safety data were obtained from three hemovigilance (HV) programs in routine use without patient selection: the Cerus hemovigilance program and the regulatory surveillance programs in France and in Switzerland.<sup>44-59</sup> Additional data were derived from an investigator-initiated post marketing retrospective observational study over a 5-year period of INTERCEPT Platelets stored for up to 7-days at a single institution in Basel, Switzerland.

The populations monitored in the Cerus hemovigilance studies (CLI-HV 00045, HV1-075-RF-HIV CTR and HV2-489-P-NIV-CTR) included 4,067 patients, where 62 patients were under the age of 1 year and 185 patients were 1-18 years of age. 50% of the patients enrolled in these studies were hematology-oncology patients, of which 12% were HSCT patients. Adverse events within 24 hours and serious adverse events within 7 days of platelet transfusion were reported. The frequencies of adverse events attributed to INTERCEPT Platelet transfusions were not increased compared to conventional platelet transfusions reported in European regulatory hemovigilance programs.

In November 2017 the Établissement Français du Sang (EFS) and the French military converted the national platelet supply to 100% INTERCEPT Platelets. The shelf-life for INTERCEPT Platelets in France was extended from 5 to 7 days in 2018-19.<sup>61</sup> Prior to the conversion, France implemented INTERCEPT Platelets in select regions in the French mainland and overseas territories accounting for between 7% and 21.4% of the French platelet supply.

Based on the ANSM hemovigilance data, transfusion reaction (TR) rates were analyzed for two 3-year periods before (2015-2017) (P1) and after (2018-2020) (P2) INTERCEPT Platelets became the national standard of care in France. A total of 801,047 conventional platelets were issued in France during P1 (79% of the national platelet supply). Fifteen (15) transfusion-transmitted bacterial infections (TTBI) were associated with conventional platelets (0.0016%) in P1 (range: 2-9 TTBI per year). One TTBI (6.7%) resulted in a fatality and 5 (33%) were life-threatening (severity grade 3). No TTBI were reported for 977,989 INTERCEPT Platelets issued in P2 following the adoption of INTERCEPT for all platelets and the incremental transition to 7-day platelet storage. Mean overall TR rates per 100,000 platelets issued were 425.4 in P1 and 367.1 in P2. No cases of viral infections against which INTERCEPT is effective or TA-GVHD were reported with INTERCEPT Platelets in either period. The mean rate of grade 3 TRs was 7.6 and 5.2 per 100,000 platelet concentrates issued in P1 and P2.

Swissmedic and the Blood Transfusion Service of the Swiss Red Cross Switzerland completed implementing the INTERCEPT Blood System for platelets in November 2011. In 2015, Swissmedic evaluated changes in the national platelet safety profile between 2008-2011 (prior to and during the INTERCEPT roll-out) and 2011-2015 (after the completion of the roll-out), based on Swiss hemovigilance data. All platelets transfused during the first period (2008-2011) were approved for 5-days storage; however, Switzerland approved INTERCEPT Platelets for storage up to 7 days in 2013, midway through the second evaluation period. A total of 93,600 conventional platelets were transfused in the first period, compared to 167,200 INTERCEPT Platelets transfused in the second period. There were 344 and 448 probable/definite related TR reports in the first and second period, respectively; and 33 and 19 probable/definite related TR rated as grade 3 (life-threatening) or grade 4 (death) reports in the first and second period, respectively.<sup>57</sup>

The majority of TRs reported to the Swissmedic hemovigilance system in 2020 were non-severe and related to febrile non-hemolytic transfusion reactions and allergic reactions. No cases of TA-GVHD or TTBI have ever been associated with INTERCEPT Platelets transfused in Switzerland.<sup>57</sup>

A retrospective Phase IV, observational, two treatment period cohort study analyzed post marketing data with INTERCEPT Platelets stored for up to 7 days.<sup>60</sup> Data were retrospectively collected for all patients who received any platelet component or RBC at a single site, Basel University Hospital in Basel, Switzerland, for two consecutive 5-year periods. Periods were defined as transfusions performed before (pre-INTERCEPT) and after (post-INTERCEPT) universal adoption of pathogen inactivation with extended platelet component storage from midway through the second evaluation period. The reference product was conventionally prepared apheresis platelet components suspended in platelet additive solution (PAS-B, T-Sol) with plasma. The conventional platelets were stored for 5 days, were not screened for bacteria, and were universally gamma irradiated to prevent transfusion-associated graft-versus-host disease (TA-GVHD). The test product was INTERCEPT Platelets suspended in approximately 65% platelet additive solution (PAS-C, InterSol) and 35% plasma. The number of conventional platelet components transfused was 14,181 in the pre-INTERCEPT phase, and 22,579 INTERCEPT Platelet components were transfused in the post-INTERCEPT phase and 3,750 of them (16.6%) were stored for more than 5 days and up to 7 days. No increase platelet and RBC usages were observed on the same day or the next day after transfusions of INTERCEPT platelets stored more than 5 days compared to after transfusions of INTERCEPT platelets stored  $\leq 5$  days.

## DEVICE PERFORMANCE

### Pathogen Inactivation

The INTERCEPT Blood System for Platelets has been tested against a broad spectrum of pathogens and demonstrated inactivation of viruses, bacteria, parasites, and donor leukocytes. Selection of pathogens was intended to provide evidence of the broad capabilities of the inactivation process. Pathogens selected represent those associated with transfusion transmission as well as model viruses of more general applicability. **Table 2** through **Table 6** summarize the pathogen inactivation data expressed as log (cfu (bacteria), pfu (viruses) or TCID<sub>50</sub> (DHBV, Borrelia, and parasites)/mL).

Legend for **Table 2** through **Table 4** and **Table 6**:

- Where a “>” is shown, the limit of the inactivation capacity was not reached in the study.
- Where a “≥” is shown, residual organisms were detected in some but not all replicates in the study.
- Where no symbol is shown, the inactivation capacity could be precisely calculated from the study results.
- Where “–” is shown, the pathogen was not tested in the indicated suspension medium.

### Viruses:

The INTERCEPT Blood System for platelets has been shown to inactivate a variety of viruses. **Table 2** lists pathogen inactivation values assessed immediately after illumination, since most viruses that potentially contaminate platelets do not readily replicate in enucleated cells. Certain non-enveloped viruses such as Calicivirus have demonstrated limited inactivation with the INTERCEPT system (**Table 3**). Parvovirus B19, HEV and HAV, similar non-enveloped viruses are expected to be resistant to inactivation with INTERCEPT.

**Table 2 Viral Inactivation (Enveloped)**

Pathogen	Extent of Inactivation (Log <sub>10</sub> pfu/mL Reduction)		
	Platelets in Plasma/InterSol	Platelets in Plasma/SSP+ <sup>a</sup>	Platelets in 100% Plasma
HIV-1 IIIB, cell-associated	≥5.4	>5.5	-
HIV-1 IIIB, cell-free	≥5.6	-	≥4.7
HIV-1 Z84 (clinical isolate)	>3.3	-	-
HIV-2 CLB-20 (clinical isolate)	>2.4	-	-
DHBV <sup>b</sup>	≥4.8	-	-
BVDV	>4.4	-	>3.3
HTLV-I	4.7	-	-
HTLV-II	5.1	-	-
Cytomegalovirus (CMV)	>4.9	-	-
PRV (model for CMV)	-	-	>4.2
Influenza A virus	≥5.9	-	-

“-” indicates not tested

a. The pathogen inactivation studies in SSP+ were carried out using the Small Volume (SV) processing set.

b. Log reduction value was calculated as log (TCID<sub>50</sub>/mL)

**Table 3 Viral Inactivation (Non-Enveloped)**

Pathogen	Extent of Inactivation (Log <sub>10</sub> pfu/mL Reduction)		
	Platelets in Plasma/InterSol	Platelets in Plasma/SSP+ <sup>a</sup>	Platelets in 100% Plasma
Calicivirus (model non-enveloped virus)	2.1	-	-
Blue Tongue virus (model non-enveloped virus)	4.4	>4.0	-

“-” indicates not tested

a. The pathogen inactivation studies in SSP+ were carried out using the Small Volume (SV) processing set.

### **Bacteria:**

The INTERCEPT Blood System for platelets has been shown to inactivate a variety of Gram-positive, Gram-negative, and spirochete bacteria. The results of these studies are summarized in **Table 4** and **Table 5**. The majority of studies were performed to assess the limits of pathogen inactivation capacity and as a result, were tested post illumination (**Table 4**). Because residual bacteria may have replication potential in platelets, a subset of studies in platelet additive solution was also performed at the end of 7-day storage (**Table 5**). The INTERCEPT process is not effective against *Bacillus cereus* spores.

**Table 4 Bacterial Inactivation (tested post-illumination)\***

Pathogen	Extent of Inactivation (Log <sub>10</sub> cfu/mL Reduction)		
	Platelets in Plasma/InterSol	Platelets in Plasma/SSP+ <sup>a</sup>	Platelets in 100% Plasma
<b>Gram-Negative Bacteria</b>			
<i>Klebsiella pneumonia</i>	5.8	>6.1	-
<i>Escherichia coli</i>	≥6.3	-	-
<i>Pseudomonas aeruginosa</i>	≥3.9	≥4.0	-
<i>Salmonella choleraesuis</i>	6.2	-	-
<i>Enterobacter cloacae</i>	5.5	-	-
<i>Yersinia enterocolitica</i>	≥5.9	-	-
<b>Gram-Positive Bacteria</b>			
<i>Staphylococcus epidermidis</i>	≥6.1	>5.7	-
<i>Staphylococcus aureus</i>	≥5.4	-	-
<i>Corynebacterium minutissimum</i>	≥5.3	-	-
<i>Bacillus cereus (vegetative)</i>	≥5.5	-	-
<b>Anaerobic Gram-Positive Bacteria and Spirochete Bacteria</b>			
<i>Borrelia burgdorferi</i> <sup>b</sup>	>6.8	-	-

“-” indicates not tested

\* Tested immediately post illumination (without storage).

a. The pathogen inactivation studies in SSP+ were carried out using the Small Volume (SV) processing set.

b. Log reduction value was calculated as log (TCID<sub>50</sub>/mL)

**Table 5 Bacterial Inactivation (tested after 7 days of storage) (Platelets in Plasma/SSP+)\***

Gram-Negative Bacteria	Input Titer (log cfu/mL)	Result at 7 days (Platelets in Plasma / SSP+)
<i>Klebsiella pneumonia</i>	2.9	No organisms detected at outdate
<i>Serratia marcescens</i>	4.6	No organisms detected at outdate
<i>Pseudomonas aeruginosa</i>	5.4	No organisms detected at outdate
Gram-Positive Bacterium	Input Titer (log cfu/mL)	Result at 7 days (Platelets in Plasma / SSP+)
<i>Staphylococcus epidermidis</i>	6.8	No organisms detected at outdate
<i>Staphylococcus aureus</i>	7.7	No organisms detected at outdate
<i>Cutibacterium acnes</i>	6.9	No organisms detected at outdate

\*These studies were carried out at 8 days post-collection and 6 days post-INTERCEPT treatment.

**Table 6 Protozoa and Leukocyte Inactivation**

Pathogen	Extent of Inactivation (Log <sub>10</sub> Reduction)		
	Platelets in Plasma/InterSol	Platelets in Plasma/SSP+	Platelets in 100% Plasma
<i>Plasmodium falciparum</i> *	≥5.6	-	-
Human T-cells**	>4	-	-

"-" indicates not tested

\*iRBC/mL

\*\*T-cell/mL

### Leukocyte Inactivation

Irradiation of blood components to inactivate leukocytes (T-cells) is frequently performed to prevent TA-GVHD in blood product recipients. The INTERCEPT Blood System has been shown to be effective in inactivating leukocytes, eliminating leukocyte replication and also inhibiting cytokine production. In France and Switzerland, no cases of TA-GVHD were reported in INTERCEPT Platelet recipients between 2010-2020, a period during which more than 1.5 million INTERCEPT Platelet components were transfused in these countries (>1.2 million in France, >300,000 in Switzerland), and both countries moved to adopt INTERCEPT Platelets as the national standard of care.<sup>50-59</sup>

Both INTERCEPT treatment and gamma irradiation inactivate leukocytes. Using a limiting dilution assay (LDA), the INTERCEPT Blood System demonstrates reduction of viable T-cells comparable to a 2,500 cGy treatment of gamma irradiation (5-6 log<sub>10</sub> inactivation).<sup>16,17</sup>

- INTERCEPT treatment results in approximately one amotosalen adduct per 83 base pairs, a sufficient frequency to ensure inactivation of most genes.<sup>18</sup>
- In an *in vitro* study, both untreated and gamma irradiated platelet samples spiked with high levels of leukocytes had significant levels of interleukin 8 after 5 to 7 days of storage, while cytokine production was substantially inhibited in the sample treated with amotosalen and UVA light.<sup>19</sup>
- In an *in vivo* murine transfusion model, mice receiving untreated splenic leukocytes developed TA-GVHD, while mice infused with gamma irradiated (2,500 cGy) or INTERCEPT treated splenic leukocytes remained healthy and did not develop TA-GVHD.<sup>20</sup>

***In vitro* Characterization of Platelet Components Processed with the INTERCEPT Blood System.**

*In vitro* platelet function characteristics were evaluated in paired *in vitro* studies of INTERCEPT apheresis platelet components and INTERCEPT whole-blood derived buffy coat platelets compared to untreated (Control) platelet components or platelet components derived from different collection methods. *In vitro* platelet function of the platelet components was evaluated on day 5 and/or day 7 after donation. The physical and metabolic characteristics evaluated for each study are included in [Table 7a](#), [Table 7b](#), [Table 7c](#), [Table 7d](#) and [Table 7e](#).

***Apheresis-derived Platelets in 100% Plasma***

Double-dose Amicus platelets containing 5.4 to 10.6 x10<sup>11</sup> platelets in 100% plasma were split evenly to produce an untreated Control and an INTERCEPT Platelet using the INTERCEPT Blood System for Platelets dual storage (DS) platelet processing set and stored for 7 days post-donation.

**Table 7a In Vitro Platelet Function Characteristics of INTERCEPT and Control Apheresis Platelets in 100% plasma After 7 Days of Storage (Mean ±SD, [range])**

Parameter (Units)	Day 5 mean ±SD and [range]			Day 7 mean ±SD and [range]		
	INTERCEPT Treated Test PC	Untreated Control PC	N	INTERCEPT Treated Test PC	Untreated Control PC	N
<b>Apheresis Platelet Components Suspended in 100% Plasma (SUD 00666)</b>						
Component Volume (mL)	294 ±6 [284-300]	297 ±3 [294-303]	7	283 ±4 [275-287]	289 ±4 [285-297]	6
Platelet Count (x10 <sup>6</sup> /mL)	1108 ±215 [790-1373]	1255 ±246 [906-1611]	7	1286 ±266 [895-1647]	1153 ±167 [912-1353]	6
Platelet Dose (x10 <sup>11</sup> /unit)	3.3 ±0.6 [2.3-3.9]	3.7 ±0.7 [2.7-4.8]	7	3.6 ±0.7 [2.6-4.5]	3.3 ±0.4 [2.7-3.9]	6
pH (22°C)	7.30 ±0.15 [7.13-7.54]	7.38 ±0.19 [7.03-7.65]	7	7.13 ±0.31 [6.59-7.49]	7.06 ±0.23 [6.86-7.35]	6
pO <sub>2</sub> (mmHg)	160 ±5 [154-168]	141 ±13 [117-161]	7	159 ±12 [139-175]	164 ±3 [159-169]	6
pCO <sub>2</sub> (mm Hg)	14 ±1 [12-15]	17 ±2 [15-20]	7	16 ±3 [11-19]	13 ±1 [12-15]	6
HCO <sub>3</sub> (mM)	6.4 ±3.7 [2.3-12.2]	9.2 ±5.1 [0-16.3]	7	4.5 ±4.5 [0-12]	2.5 ±3.8 [0-7.6]	6
Glucose (mg/dL)	199 ±16 [179-225]	222 ±32 [165-264]	7	173 ±45 [102-231]	159 ±27 [130-191]	6
Lactate (mM)	13.0 ±2.2 [10.4-15.7]	12.2 ±3.8 [8.2-19.4]	7	16.6 ±4.9 [10.8-25.1]	16.9 ±3.0 [13-20.4]	6
LDH (U/L)	420 ±69 [316-535]	373 ±56 [285-441]	7	373 ±54 [304-426]	430 ±81 [305-545]	6
Swirling	+	+	7	+	+	6
MPV (µm <sup>3</sup> )	7.3 ±0.6 [6.8-8.6]	7.4 ±0.7 [6.8-8.7]	7	7.3 ±0.4 [6.7-7.6]	7.3 ±0.4 [6.7-7.8]	6
p-selectin (ng/mL)	210 ±18 [184-235]	225 ±19 [195-248]	7	261 ±22 [224-276]	270 ±39 [217-313]	6

PC = platelet concentrate

*Apheresis-Derived Platelets in Additive Solution (PAS-C, InterSol)*

Single-dose and double-dose Amicus platelets containing  $2.9$  to  $8.0 \times 10^{11}$  platelets in 35% plasma/65% PAS-C were either stored untreated (Control) or treated with the INTERCEPT Blood System for Platelets dual-storage (DS) platelet processing set and stored for 7 days post-donation.

**Table 7b In Vitro Platelet Function Characteristics of INTERCEPT and Control Apheresis Platelets in InterSol After 7 Days of Storage (Mean  $\pm$ SD, [range])**

Parameter (Units)	Day 5 mean $\pm$ SD and [range]			Day 7 mean $\pm$ SD and [range]		
	INTERCEPT Treated Test PC	Untreated Control PC	N	INTERCEPT Treated Test PC	Untreated Control PC	N
<b>Double and Single Dose Apheresis Platelet Components Suspended in InterSol (CLI 00094)</b>						
<b>Platelet Component Characteristics</b>						
Component volume (mL)	279 $\pm$ 74 [162-382]	288 $\pm$ 74 [152-400]	63	262 $\pm$ 65 [147-360]	272 $\pm$ 66 [150-382]	63
Platelet Count ( $\times 10^6$ /mL)	1383 $\pm$ 341 [717-2002]	1482 $\pm$ 375 [730-2250]	63	1350 $\pm$ 310 [720-1945]	1445 $\pm$ 373 [678-2323]	63
Platelet Dose ( $\times 10^{11}$ /unit)	3.7 $\pm$ 0.8 [2.5-6.1]	4.0 $\pm$ 0.6 [2.3-5.5]	63	3.4 $\pm$ 0.7 [2.4-5.7]	3.7 $\pm$ 0.5 [2.0-4.7]	63
MPV (fL)	8.1 $\pm$ 0.8 [6.7-10.6]	8.1 $\pm$ 0.9 [6.7-10.4]	58	8.3 $\pm$ 1.0 [6.5-11.3]	8.2 $\pm$ 1.0 [6.6-10.4]	55
<b>Indices of Platelet Metabolism</b>						
pH (22°C)	7.02 $\pm$ 0.11 [6.78-7.20]	7.03 $\pm$ 0.12 [6.73-7.25]	63	7.06 $\pm$ 0.09 [6.86-7.24]	7.10 $\pm$ 0.10 [6.83-7.35]	63
pO <sub>2</sub> (mm Hg)	130 $\pm$ 2 [66-168]	124 $\pm$ 20 [70-154]	63	133 $\pm$ 17 [90-174]	123 $\pm$ 21 [70-160]	63
pCO <sub>2</sub> (mm Hg)	20 $\pm$ 6 [10-32]	24 $\pm$ 6 [13-35]	63	18 $\pm$ 5 [10-26]	21 $\pm$ 5 [10-30]	63
HCO <sub>3</sub> <sup>-</sup> (mmol/L)	3.2 $\pm$ 1.1 [1.0-5.3]	3.8 $\pm$ 1.3 [2.0-7.0]	60	3.1 $\pm$ 0.9 [2.0-5.0]	3.9 $\pm$ 1.2 [1.0-6.0]	56
Supernatant glucose (mg/dL)	21.5 $\pm$ 24.0 [0.0-127.8]	15.5 $\pm$ 23.3 [0.0-120.6]	61	6.6 $\pm$ 15.3 [0.0-102.6]	6.1 $\pm$ 15.1 [0.0-99.0]	61
Supernatant lactate (mmol/L)	11 $\pm$ 2 [7-15]	12 $\pm$ 3 [7-19]	63	12 $\pm$ 2 [8-15]	13 $\pm$ 2 [9-18]	63
Total ATP (nmol/10 <sup>8</sup> Plts)	4.70 $\pm$ 1.95 [1.07-9.39]	4.47 $\pm$ 1.72 [1.20-10.25]	63	4.34 $\pm$ 1.76 [0.12-8.45]	4.22 $\pm$ 1.51 [1.21-10.08]	63
<b>Indices Correlating with In Vivo Recovery, Survival and Function</b>						
Morphology	257 $\pm$ 47 [176-360]	251 $\pm$ 45 [186-360]	63	235 $\pm$ 44 [158-335]	233 $\pm$ 44 [124-340]	63
Extent of Shape Change (ESC; %)	12.2 $\pm$ 8.1 [1.0-49.0]	11.9 $\pm$ 9.1 [0.0-32.6]	63	10.8 $\pm$ 6.2 [0.0-20.7]	11.7 $\pm$ 7.2 [0.0-27.0]	63
Hypotonic Shock Response (HSR; %)	28 $\pm$ 18 [0-56]	30 $\pm$ 19 [0-62]	63	25 $\pm$ 14 [0-51]	28 $\pm$ 18 [0-55]	62

Parameter (Units)	Day 5 mean $\pm$ SD and [range]			Day 7 mean $\pm$ SD and [range]		
	INTERCEPT Treated Test PC	Untreated Control PC	N	INTERCEPT Treated Test PC	Untreated Control PC	N
<b>Indices of Granular and Cytoplasmic Content Retention</b>						
LDH activity (IU/L)	149 $\pm$ 92 [10-581]	142 $\pm$ 83 [60-460]	63	198 $\pm$ 104 [74-586]	177 $\pm$ 83 [74-549]	63
LDH (IU/10 <sup>12</sup> Plts)	110 $\pm$ 54 [8-329]	97 $\pm$ 49 [35-270]	63	155 $\pm$ 85 [39-382]	127 $\pm$ 60 [40-322]	63
P-selectin (%)	36.98 $\pm$ 16.22 [7.93-83.31]	33.70 $\pm$ 13.96 [9.28-74.47]	60	40.96 $\pm$ 13.39 [9.47-78.83]	35.40 $\pm$ 13.56 [11.06-77.28]	60

PC = platelet concentrate

*Apheresis- and Buffy Coat-Derived Platelets in Additive Solution (PAS-E, SSP+)*

Double-dose Trima platelets and pooled whole blood derived buffy coat platelets containing  $8.0 \times 10^{11}$  platelets in 35% plasma/65% SSP+ were treated with the INTERCEPT Blood System for Platelets dual-storage (DS) platelet processing set and stored for 7 days post-donation.

**Table 7c In Vitro Platelet Function Characteristics of INTERCEPT Platelets in SSP+ After 5 and 7 Days of Storage (Mean  $\pm$ SD)**

Parameter (Units)	Day 5		Day 7	
	INTERCEPT Treated Buffy Coat Platelets (n=6)	INTERCEPT Treated Apheresis Platelets (n=13)	INTERCEPT Treated Buffy Coat Platelets (n=6)	INTERCEPT Treated Apheresis Platelets (n=13)
<b>Platelet Components Suspended in SSP+ (REL-R 00417)</b>				
<b>Platelet Component Characteristics</b>				
Component volume (mL)	193 $\pm$ 6	186 $\pm$ 4	183 $\pm$ 6	176 $\pm$ 4
Platelet Dose ( $\times 10^{11}$ /unit)	3.4 $\pm$ 0.2	3.6 $\pm$ 0.4	3.2 $\pm$ 0.2	3.3 $\pm$ 0.4
<b>Indices of Platelet Metabolism</b>				
pH (22°C)	7.25 $\pm$ 0.04 <sup>a</sup>	7.25 $\pm$ 0.08	7.20 $\pm$ 0.04	7.26 $\pm$ 0.10
pO <sub>2</sub> (mm Hg)	78.5 $\pm$ 24.0 <sup>a</sup>	44.7 $\pm$ 24.0 <sup>b</sup>	79.5 $\pm$ 29.4 <sup>a</sup>	57.3 $\pm$ 18.0
pCO <sub>2</sub> (mm Hg)	21.5 $\pm$ 1.6 <sup>a</sup>	24.0 $\pm$ 2.7	21.5 $\pm$ 1.7	19.9 $\pm$ 2.0
HCO <sub>3</sub> <sup>-</sup> (mmol/L)	8.3 $\pm$ 0.7 <sup>a</sup>	8.6 $\pm$ 1.3	7.5 $\pm$ 0.7	8.2 $\pm$ 1.8
Glucose (mmol/L)	5.09 $\pm$ 0.73	2.79 $\pm$ 1.14 <sup>c</sup>	2.68 $\pm$ 0.58	NC <sup>d</sup>
Lactate (mmol/L)	10.45 $\pm$ 0.87	8.25 $\pm$ 1.22	13.05 $\pm$ 0.93	10.27 $\pm$ 0.81
ATP (nmol/10 <sup>8</sup> Plts)	4.23 $\pm$ 0.14	4.42 $\pm$ 0.53	4.01 $\pm$ 0.15	3.95 $\pm$ 0.55

a n=5; b n=12; c n=11; d NC=not calculated



*Buffy Coat-Derived Platelets in Additive Solution (PAS-C, InterSol)*

Pools of 10 to 12 whole-blood derived buffy coat platelets in 36 to 42% plasma/58-64% PAS-C were split evenly to produce an untreated Control and an INTERCEPT Platelet using the INTERCEPT Blood System for Platelets large volume (LV) platelet processing set and stored for 7 days post-donation.

**Table 7d In Vitro Platelet Function Characteristics of INTERCEPT and Control Whole Blood Derived Buffy Coat Platelets in InterSol After 7 Days of Storage (Mean  $\pm$ SD)**

Parameter (Units)	Day 5 mean $\pm$ SD			Day 7 mean $\pm$ SD		
	INTERCEPT Treated Test PC	Untreated Control PC	N	INTERCEPT Treated Test PC	Untreated Control PC	N
<b>Whole-Blood Derived, Single Dose Platelet Components Suspended in InterSol (148-REP-NIV-FE-505)</b>						
Parameter (Units)	INTERCEPT Treated Test PC	Untreated Control PC	N	INTERCEPT Treated Test PC	Untreated Control PC	N
Component Volume (mL)	331 $\pm$ 23	346 $\pm$ 20	6	324 $\pm$ 24	338 $\pm$ 23	6
Platelet Count (x10 <sup>6</sup> /mL)	870 $\pm$ 68	928 $\pm$ 77	6	852 $\pm$ 90	922 $\pm$ 72	6
Platelet Dose (x10 <sup>11</sup> /unit)	2.9 $\pm$ 0.3	3.2 $\pm$ 0.3	6	2.8 $\pm$ 0.4	3.1 $\pm$ 0.3	6
pH (22°C)	7.25 $\pm$ 0.02	7.32 $\pm$ 0.03	6	7.20 $\pm$ 0.03	7.28 $\pm$ 0.08	6
pO <sub>2</sub> (mmHg)	18.8 $\pm$ 2.1	19.7 $\pm$ 1.8	6	18.5 $\pm$ 2.0	16.1 $\pm$ 3.6	6
pCO <sub>2</sub> (mm Hg)	3.0 $\pm$ 0.2	3.3 $\pm$ 0.2	6	2.9 $\pm$ 0.3	3.4 $\pm$ 0.2	6
HCO <sub>3</sub> (mmol/L)	5.7 $\pm$ 0.6	6.9 $\pm$ 0.6	6	4.6 $\pm$ 0.8	6.0 $\pm$ 0.7	6
Glucose (mmol/L)	4.8 $\pm$ 0.5	5.2 $\pm$ 0.6	6	3.3 $\pm$ 0.5	3.6 $\pm$ 0.5	6
Lactate (mmol/L)	12.3 $\pm$ 0.9	12.6 $\pm$ 0.9	6	15.4 $\pm$ 1.1	15.7 $\pm$ 1.0	6
ATP	4.9 $\pm$ 0.3	5.3 $\pm$ 0.5	6	4.7 $\pm$ 0.3	5.2 $\pm$ 0.4	6

PC = platelet concentrate

*Apheresis and Buffy Coat-Derived Platelets in Additive Solution (PAS-C, InterSol)*

Double-dose Trima platelets containing  $7.2 \times 10^{11}$  platelets in 41% plasma/59% PAS-C and pooled whole blood derived buffy coat platelets containing  $6.9 \times 10^{11}$  platelets in 42% plasma/58% PAS-C were treated with the INTERCEPT Blood System for Platelets dual-storage (DS) platelet processing set and stored for 7 days post-donation.

**Table 7e In Vitro Platelet Function Characteristics of INTERCEPT Apheresis and Whole Blood Derived Buffy Coat Platelets in InterSol After 7 Days of Storage (Mean  $\pm$ SD)**

Parameter (Units)	Day 5 (mean $\pm$ SD)		Day 7 (mean $\pm$ SD)	
	INTERCEPT Treated Buffy Coat PC (n=17)	INTERCEPT Treated Apheresis PC (n=15)	INTERCEPT Treated Buffy Coat PC (n=17)	INTERCEPT Treated Apheresis PC (n=15)
<b>Apheresis and Whole Blood Derived Buffy Coat Platelet Components Suspended in Intersol (REL-R 00492)</b>				
pH (22°C)	7.00 $\pm$ 0.08	7.08 $\pm$ 0.09	7.02 $\pm$ 0.08	7.05 $\pm$ 0.08
pO <sub>2</sub> (mmHg) at +37°C	112.4 $\pm$ 20.2	111.1 $\pm$ 15.4	125.8 $\pm$ 22.8	119.0 $\pm$ 16.8
pCO <sub>2</sub> (mmHg) at +37°C	20.0 $\pm$ 2.8	19.1 $\pm$ 3.7	14.7 $\pm$ 2.4	16.0 $\pm$ 4.0
Glucose (mmol/L)	1.4 $\pm$ 0.8	3.2 $\pm$ 1.5	< 0.3	1.3 $\pm$ 1.0
Lactate (mmol/L)	15.4 $\pm$ 2.5	11.5 $\pm$ 1.9	18.9 $\pm$ 1.6	15.0 $\pm$ 1.5
MPV (fL)	7.5 $\pm$ 0.6	8.4 $\pm$ 1.9	7.6 $\pm$ 0.6	8.4 $\pm$ 1.8
LDH (U/L)	166 $\pm$ 27	159 $\pm$ 39	218 $\pm$ 43	180 $\pm$ 41
p-selectin (ng/mL)	80.3 $\pm$ 10.0	139.4 $\pm$ 56.1	125.8 $\pm$ 16.6	176.8 $\pm$ 60.0
Swirling index <sup>a</sup>	POS	POS	POS	POS

PC = platelet concentrate

a. POS corresponds to the presence of swirling. It is equivalent to the result +++.

Together these studies support the comparability of INTERCEPT-treated apheresis or whole blood-derived buffy coat platelets in platelet additive solution with untreated platelets through 7 days of storage. In addition, these studies support the comparability of INTERCEPT-treated platelets in 100% plasma with untreated platelets through 5 days of storage. All units met CSA/CAN-Z902 for pH (22°C) of 6.4-7.8 and local, or study design, requirements for platelet dose.

## INSTRUCTIONS FOR USE

- Do not use if: tamper-evident package has been opened; signs of deterioration or damage are visible; fluid path closures are loose or not intact; cannulae are broken; there is no fluid in amotosalen solution container; CAD is bent or broken; base labels are not legible, accurate, or are missing.
- Do not freeze. Do not store above 25°C. Do not vent. Protect the pack and tubing from sharp objects.
- Sets removed from the aluminum foil must be used within **8 hours**.
- Record the Date Opened on the foil pouch label in space provided.
- Unused sets may be kept **20 days** at room temperature in open aluminum foil by folding and securing open end of aluminum foil. Record the Use By date on the foil pouch label in space provided.
- Keep set in light-protective package until time of use. Protect from direct sunlight and strong UVA light source.
- Set is single use only.

This process is designed to be a closed system. Treatment with INTERCEPT Blood System does not replace applicable standards for processing in open and closed systems. If there is a leak in the set during processing, platelet product must be discarded.

## MATERIALS AND EQUIPMENT

**Materials Provided:** One (1) INTERCEPT Dual Storage Processing Set

**Equipment Provided Separately:** INTERCEPT Illuminator, Platelet Additive Solutions [PAS-C, InterSol (manufactured by Fenwal, Inc and supplied by Cerus upon request) and PAS-E, SSP+ (manufactured by Maco Pharma)] are the only platelet additive solutions currently approved in Canada for use with the INTERCEPT Blood System.

**Equipment Required but Not Provided:** Sterile Connecting Device (SCD), Tube Sealer, Flatbed Agitator, Manual Tube Clamp (e.g., Hemostat)

Temperatures should be controlled to meet applicable regulations for platelet processing. Used and unused INTERCEPT sets should be discarded like any used blood containers, as biohazardous waste.

**Figure 3 INTERCEPT Dual Storage Processing Set**

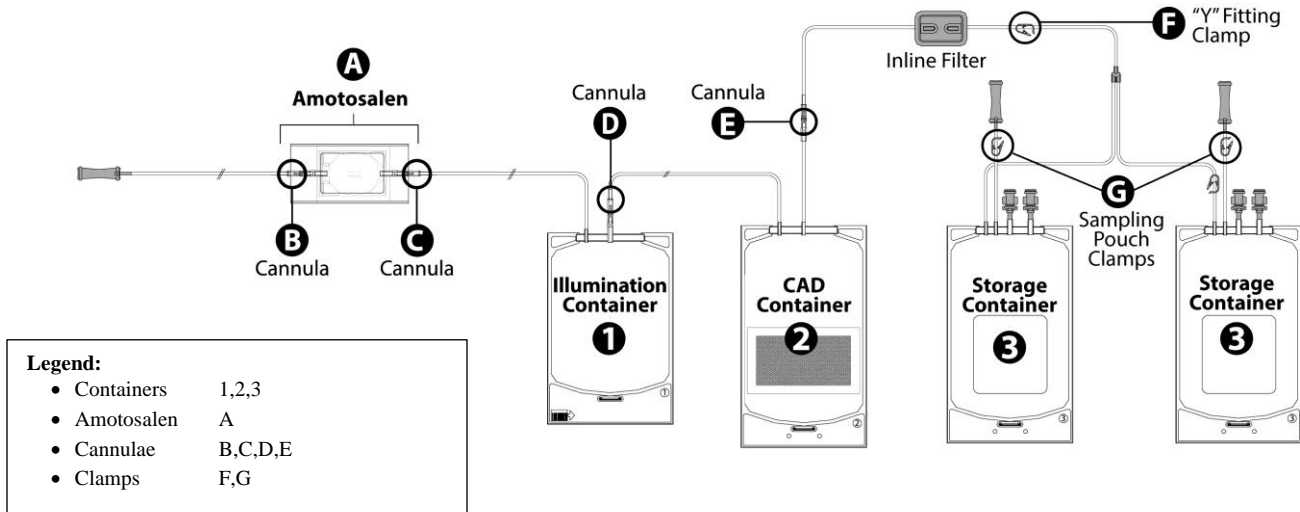

**Performing the INTERCEPT Treatment Process**

Instructions refer to [Figure 3](#) for labeling and identification of set components.

All the following conditions must be met for pathogen inactivation:

- Platelet source, content, volume, and red blood cell (RBC) count must be within the ranges specified in [Table 8](#).
- Follow apheresis device instructions for platelet handling and resting procedures prior to INTERCEPT treatment.
- Platelets should meet institutional specifications for aggregates prior to INTERCEPT treatment.
- Platelets mixed with amotosalen must be exposed to UVA light dose from INTERCEPT Illuminator. No other source of UVA light may be used.
- Platelets collected on Day 0 must be exposed to UVA light by end of Day 1.
- After illumination, platelets must be agitated in CAD container in accordance with the duration specified in [Table 9](#).

## I. Preparation of Platelets

Platelet products within the following ranges have been shown to be acceptable for use with this processing set (Table 8).

**Table 8 Platelet Collection Specifications for INTERCEPT Dual Storage Processing Set**

	Suspension Medium: PAS		Suspension Medium: 100% Plasma	
Platelet Source	Apheresis, Whole Blood-Derived Buffy Coat Platelets		Apheresis	
PAS	InterSol® (PAS-C) or SSP+ (PAS-E)		Not Applicable	
Input Platelet Volume	300 – 420 mL	375 – 420 mL	300 – 375 mL	375 – 420 mL
Platelet Dose	$2.5 - 7.0 \times 10^{11}$	$7.1 - 8.0 \times 10^{11}$	$2.5 - 7.0 \times 10^{11}$	$7.1 - 8.0 \times 10^{11}$
PAS Content	53 – 68%	53 – 68%	0%	0%
Plasma Content	32 – 47%	32 – 47%	100%	100%
RBC Content	$< 4 \times 10^6$ RBC/mL	$< 4 \times 10^6$ RBC/mL	$< 4 \times 10^6$ RBC/mL	$< 4 \times 10^6$ RBC/mL

## II. Amotosalen Addition to Platelets

1. Remove set from package. Unwrap only illumination container (1) from organizer.
2. Weld tubing from platelet collection container to amotosalen container (A) tubing using SCD.
3. Label storage container (B) using appropriate donation identification.
4. Hang platelet collection container and break cannula (C) below amotosalen container (A) to let amotosalen flow into illumination container (1); visually verify amotosalen is present.
5. Break cannula (B) above amotosalen container (A) to let platelets flow through amotosalen container (A) into illumination container (1).
6. Ensure the platelets drain completely from initial platelet collection container into illumination container (1) by expressing air from the illumination container (1) into amotosalen container (A).
7. When air is removed and platelets have fully drained back into illumination container (1), manually clamp tubing above illumination container. Mix illumination container thoroughly by gentle agitation to ensure complete mixing of amotosalen and platelets (Figure 4).

**Figure 4 Gently Agitate the Filled Illumination Container**

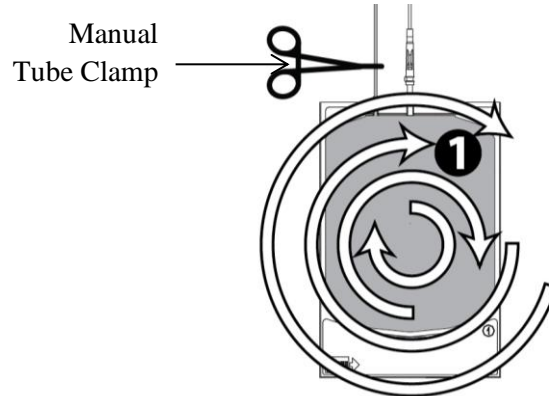

8. Open manual tube clamp and expel remainder of air in illumination container ( ❶ ) into amotosalen container ( ❸ ).
9. Express a small amount of platelet and amotosalen mixture into tubing, filling about 1.5 inches of tubing. Close manual clamp.
10. Seal tubing between illumination container ( ❶ ) and amotosalen container ( ❸ ) so that tubing is no longer than 1.5 inches from the illumination container ( ❶ ) (Figure 5 below; also refer to INTERCEPT Illuminator Operator’s Manual for further details on loading the processing set into the Illuminator).

**Warning:** During illumination, tubing must be held within large compartment of illumination tray.

**Figure 5 Heat Seal Filled Tubing Within 1.5 Inches**

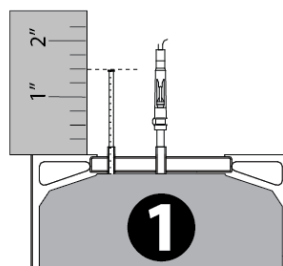

11. Remove and discard empty platelet collection container, amotosalen container ( ❸ ) and excess tubing.

### III. Illumination

Illuminate platelets.

Refer to INTERCEPT Illuminator Operator's Manual for complete illumination instructions for use.

**Warning:** All platelets, both in illumination container and tubing, must be within large compartment of illuminator tray in order for inactivation to occur. The process requires unimpeded light transmission through tray and illumination container with platelets. **No labels or other material should be on this area. Tray must be clean. Labels should be placed on illumination container flap only.** Illumination container should lay flat in order to ensure complete illumination.

**Figure 6 The Correct and Incorrect Way to Load a Processing Set Into the Illuminator Tray**

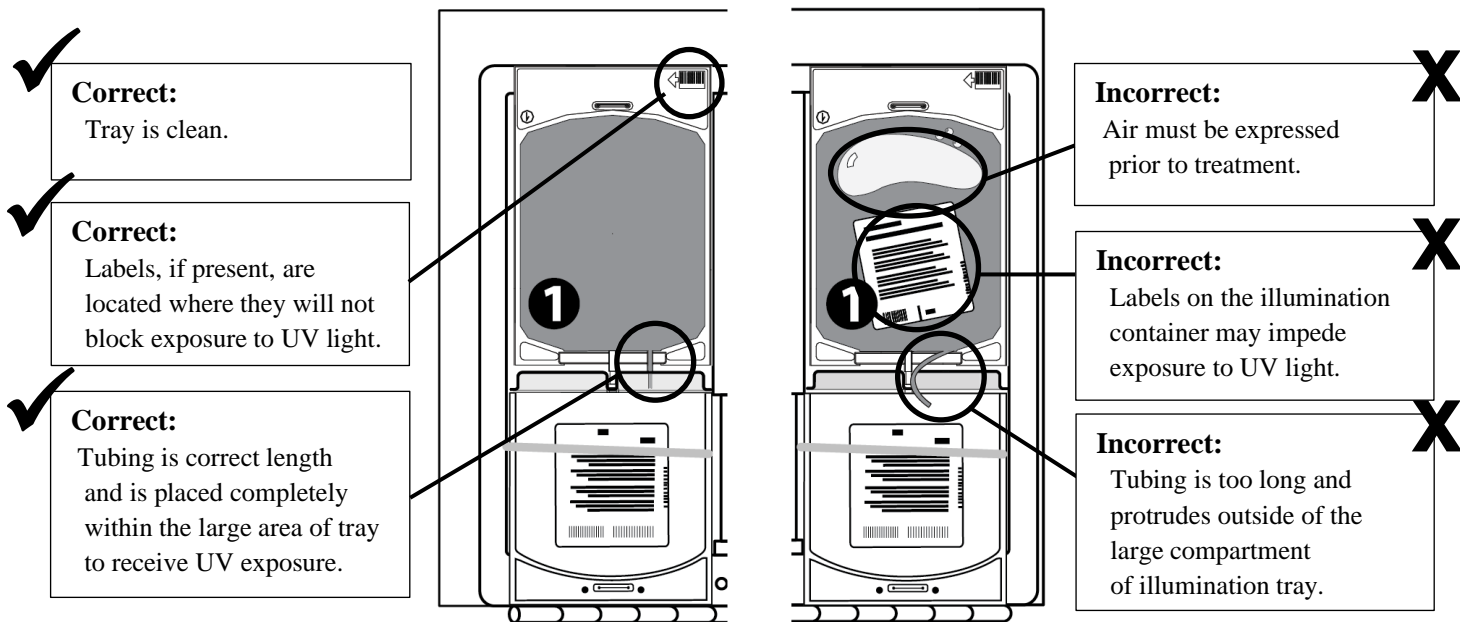

#### IV. Agitation with Compound Adsorption Device (CAD)

**Warning:** Do not fold or bend CAD.

1. Unwrap set from organizer.
2. Hang platelets in illumination container ( ❶ ), break cannula ( ❷ ) and allow platelets to flow into CAD container ( ❸ ).
3. Express air from CAD container ( ❸ ) into illumination container ( ❶ ). Do not fold or bend CAD.
4. Seal tubing close to inlet port of CAD container ( ❸ ).
5. Remove and discard empty illumination container ( ❶ ) and excess tubing.
6. Place CAD container ( ❸ ) flat on flatbed agitator with attached storage containers for duration specified in **Table 9**. Agitation rate must be at least 60 RPM.
7. Do not fold or place storage container ( ❹ ), in line filter, or any tubing under CAD container ( ❸ ) during agitation.

**Table 9 CAD Agitation Duration**

Suspension Medium	CAD Agitation Duration
PAS	6 to 16 hours
100% Plasma	16 to 24 hours

#### V. Transfer to Storage Container

1. Remove platelets from agitator and hang platelets in CAD container ( ❸ ).
2. Expel air from platelet sampling pouch and close clamp ( ❺ ).
3. Break cannula ( ❻ ) at outlet of CAD container ( ❸ ) and allow platelets to flow into storage container ( ❹ ).
4. Express air from storage container ( ❹ ) into CAD container ( ❸ ).
5. Ensure appropriate donor identification is attached to the filled platelet storage containers ( ❹ ).
6. Seal tubing to storage container ( ❹ ).
7. Remove and discard empty CAD container ( ❸ ) and tubing. Place platelets on platelet agitator.

**The INTERCEPT treatment process is now complete.**



### **Sampling Platelet Product (optional)**

1. Mix INTERCEPT treated platelets by gently agitating platelet storage container.
2. Open clamp (  ) to platelet sampling pouch and squeeze several times.
3. Allow sampling pouch to fill with platelets. Seal tubing.
4. Remove sample pouch.
5. Transfer sample to appropriate laboratory tube immediately.

### **STORAGE**

Following processing, INTERCEPT Platelets should be stored in the storage container provided in the processing sets at 20-24°C with continuous agitation.

INTERCEPT Platelets suspended in InterSol (PAS-C) or SSP+ (PAS-E) may be stored for up to 7 days from the day of collection.

INTERCEPT Platelets suspended in 100% plasma may be stored for up to 5 days from the day of collection.

## REFERENCES

1. Lin L, Hanson CV, Alter HJ, Jauvin V, Bernard KA, Murthy KK, Metzler P, Corash L. Inactivation of viruses in platelet concentrates by photochemical treatment with amotosalen and long-wavelength ultraviolet light. *Transfusion* 2005;45:580-590.
2. Jordan CT, Saakadze N, Newman JL, Lezhava LJ, Maiers TT, Hillyer WM, Roback JD, Hillyer CD. Photochemical treatment of platelet concentrates with amotosalen hydrochloride and ultraviolet A light inactivates free and latent cytomegalovirus in a murine transfusion model. *Transfusion* 2004;44:1159-1165.
3. Lin L. Inactivation of cytomegalovirus in platelet concentrates using Helinx technology. *Seminars in Hematology* 2001;38:27-33.
4. Tsetsarkin KA, Sampson-Johannes A, Sawyer L, Kinsey J, Higgs S, Vanlandingham DL. Photochemical inactivation of chikungunya virus in human apheresis platelet components by amotosalen and UVA light. *Am J Trop Med Hyg.* 2013;88(6):1163-9.
5. Musso D, Richard V, Broult J, Cao-Lormeau VM. Inactivation of dengue virus in plasma with amotosalen and ultraviolet A illumination. *Transfusion* 2014. doi: 10.1111. e-pub ahead of print.
6. Roback JD et al., CMV Safety of Platelet Products: Comparison of Inactivation of INTERCEPT Blood System and Removal of Leukofiltration. *Transfusion*; 2007a., 47(S3):23A.
7. Roback JD et al., Inactivation of Infectious CMV in Platelet Products: Comparison of Inactivation of INTERCEPT Blood System and Leukofiltration. *Blood*, 2007b., 110(11):849A.
8. Dupuis, K, D Arnold, et al., High titers of dengue virus in platelet concentrates are inactivated by amotosalen and UVA light. *Transfusion*, 2012. 52((3S)): p. 225A.
9. Sawyer, L, K Dupuis, et al., Inactivation of influenza A H5N1 and Lymphocytic Choriomeningitis virus (LCMV) by the INTERCEPT Blood System (IBS). *Transfusion*, 2008. 48(2S): p. 88A.
10. Pinna, D, A Sampson-Johannes, et al., Amotosalen photochemical inactivation of severe acute respiratory syndrome coronavirus in human platelet concentrates. *Transfus Med*, 2005. 15(4): p. 269-76.
11. Van Voorhis WC, Barrett LK, Eastman RT, Alfonso R, Dupuis K. *Trypanosoma cruzi* Inactivation in Human Platelet Concentrates and Plasma by a Psoralen (Amotosalen HCl) and Long-Wavelength UV. *Antimicrobial Agents and Chemotherapy* 2003;47:475–479.
12. Duffy T, Bisio M, Altcheh J, Burgos JM, Diez M, Levin MJ, Favaloro RR, Freilij H, Schijman AG. Accurate real-time PCR strategy for monitoring bloodstream parasitic loads in chagas disease patients. *PLoS Negl Trop Dis.* 2009;3(4):e419.
13. Grellier P, Benach J, Labaied M, Charneau S, Gil H, Monsalve G, Alfonso R, Sawyer L, Lin L, Steiert M, Dupuis K. Photochemical inactivation with amotosalen and long-wavelength ultraviolet light of Plasmodium and Babesia in platelet and plasma components. *Transfusion.* 2008;48:1676-84.
14. Sawyer, L, C Kodner, et al., Inactivation of transfusion-transmitted vector-borne pathogens. *Vox Sang*, 2009. 96(S1): p. 233.
15. Eastman, RT, LK Barrett, et al., Leishmania inactivation in human pheresis platelets by a psoralen (amotosalen HCl) and long-wavelength ultraviolet irradiation. *Transfusion*, 2005. 45(9): p. 1459-63.
16. Corash L, Lin L, Novel processes for inactivation of leukocytes to prevent transfusion-associated graft-versus-host disease. *Bone Marrow Transplant* 2004;33:1-7.
17. Luban NL, Drothler D, Moroff G, Quinones R. Irradiation of platelet components: inhibition of lymphocyte proliferation assessed by limiting-dilution analysis. *Transfusion* 2000;40:348-352.
18. Lin L, Corash L, Osselaer JC. Protection Against TA-GVHD due to platelet transfusion by using pathogen inactivation with the INTERCEPT Blood System – gamma irradiation is not the only answer. *Haematologica* 2010;95, Extra 1:230-237.
19. Hei DJ, Grass J, Lin L, Corash L, Cimino G. Elimination of cytokine production in stored platelet concentrate aliquots by photochemical treatment with psoralen plus ultraviolet A light. *Transfusion* 1999;39:239-248.
20. Grass JA, Wafa T, Reames A, Wages A, Corash L, Ferrara JL, Lin L. Prevention of transfusion-associated graft-versus-host disease by photochemical treatment. *Blood* 1999;93:3140-3147.
21. Wollowitz, S. Fundamentals of the psoralen-based Helinx technology for inactivation of infectious pathogens and leukocytes in platelets and plasma. *Semin Hematol* 2001 Oct;38(4 Suppl 11):4-11.

22. Snyder E, McCullough J, Slichter SJ, Strauss RG, Lopez-Plaza I, Lin JS, Corash L, Conlan MG. Clinical safety of platelets photochemically treated with amotosalen HCl and ultraviolet A light for pathogen inactivation: the SPRINT trial. *Transfusion* 2005; 45(12):1864-1875.
23. Corash L, Lin JS, Sherman CD, Eiden J. Determination of acute lung injury following repeated platelet transfusions. *Blood* 2011; 117(3):1014-1020.
24. van Rhenen D, Gulliksson H, Cazenave JP, Pamphilon D, Ljungman P, Klüter H, Vermeij H, Kappers-Klunne M, de Greef G, Laforet M, Lioure B, Davis K, Marblie S, Mayaudon V, Flament J, Conlan M, Lin L, Metzel P, Buchholz D, Corash L. Transfusion of pooled buffy coat platelet components prepared with photochemical pathogen inactivation treatment: the euroSPRITE trial. *Blood* 2003;101:2426-2433.
25. McCullough JI, Vesole DH, Benjamin RJ, Slichter SJ, Pineda A, Snyder E, Stadtmauer EA, Lopez-Plaza I, Coutre S, Strauss RG, Goodnough LT, Frیده JL, Raife T, Cable R, Murphy S, Howard F 4th, Davis K, Lin JS, Metzel P, Corash L, Koutsoukos A, Lin L, Buchholz DH, Conlan MG. Therapeutic efficacy and safety of platelets treated with a photochemical process for pathogen inactivation: the SPRINT Trial. *Blood* 2004;104(5):1534-1541.
26. Janetzko K, Cazenave JP, Klüter H, Kientz D, Michel M, Beris P, Lioure B, Hastka J, Marblie S, Mayaudon V, Lin L, Lin JS, Conlan MG, Flament J. Therapeutic efficacy and safety of photochemically treated apheresis platelets processed with an optimized integrated set. *Transfusion* 2005;45(9):1443-1452.
27. Lin L, Conlan MG, Tessman J, Cimino G, Porter S. Amotosalen interactions with platelet and plasma components: absence of neoantigen formation after photochemical treatment. *Transfusion* 2005;45:1610-1620.
28. Ciaravino V. Preclinical safety of nucleic acid-targeted Helinx™ compound: a clinical perspective. *Semin Hematol* 2001;38(suppl 11):12-19.
29. Ciaravino V, Hanover J, Lin L, Sullivan T, Corash L. Assessment of safety in neonates for transfusion of platelets and plasma prepared with amotosalen photochemical pathogen inactivation treatment by a 1-month intravenous toxicity study in neonatal rats. *Transfusion* 2009;49:985-994.
30. Ciaravino V, McCullough T, Dayan AD. Pharmacokinetic and toxicology assessment of INTERCEPT (S-59 and UVA treated) platelets. *Human and Experimental Toxicology* 2001;20:533-550.
31. Sigle JP, Infanti L, Studt JD, Martinez M, Stern M, Gratwohl A, Passweg J, Tichelli A, Buser AS. Comparison of transfusion efficacy of amotosalen-based pathogen-reduced platelet components and gamma-irradiated platelet components. *Transfusion* 2013;53(8):1788-1797.
32. Slichter SJ, Kaufman RM, Assmann SF, McCullough J, Triulzi DJ, Strauss RG, Gernsheimer TB, Ness PM, Brecher ME, Josephson CD, Konkle BA, Woodson RD, Ortel TL, Hillyer CD, Skerrett DL, McCrae KR, Sloan SR, Uhl L, George JN, Aquino VM, Manno CS, McFarland JG, Hess JR, Leissing C, Granger S. Dose of prophylactic platelet transfusions and prevention of hemorrhage. *N Engl J Med* 2011;362:600-613.
33. Ishida A, Handa M, Wakui M, Okamoto S, Kamakura M, Ikeda Y. Clinical factors influencing posttransfusion platelet increment in patients undergoing hematopoietic progenitor cell transplantation—a prospective analysis. *Transfusion* 1998;38:839-847.
34. Bishop JF, Matthews JP, McGrath K, Yuen K, Wolf MM, Szer J. Factors influencing 20-hour increments after platelet transfusion. *Transfusion* 1991;31:392-396.
35. Butler C, Doree C, Estcourt LJ, Trivella M, Hopewell S, Brunskill SJ, Stanworth S, Murphy MF. Pathogen-reduced platelets for the prevention of bleeding. *Cochrane Database Syst* 2013;Rev 3: CD009072.
36. Murphy S, Snyder E, Cable R, Slichter SJ, Strauss RG, McCullough J, Lin JS, Corash L, Conlan MG. Platelet dose consistency and its effect on the number of platelet transfusions for support of thrombocytopenia: an analysis of the SPRINT trial of platelets photochemically treated with amotosalen HCl and ultraviolet A light. *Transfusion* 2006;46:24-33.
37. Simonsen AC, Johansson PI, Conlan MG, Jacquet M, Lin JS, Junge K, Lin L, Sørensen H, Borregaard N, Flament J. Transfusion of 7-day-old amotosalen photochemically treated buffy-coat platelets to patients with thrombocytopenic: a pilot study. *Transfusion* 2006;46:424-433.
38. Lozano M, Knutson F, Tardivel R, Cid J, Maymó RM, Löf H, Roddie H, Pelly J, Docherty A, Sherman C, Lin L, Propst M, Corash L, Prowse C. A multi-centre study of therapeutic efficacy and safety of platelet components treated with amotosalen and ultraviolet A pathogen inactivation stored for 6 or 7 d prior to transfusion. *Br J Haematol* 2011;153(3):393-401.

39. Schlenke P, Hagenah W, Irsch J, Sundin D, Corash L, Lin L, Kirchner H, Wagner T. Safety and clinical efficacy of platelet components prepared with pathogen inactivation in routine use for thrombocytopenic patients. *Ann Hematol* 2011;90(12):1457-1465.
40. Infanti L, Stebler C, Job S, Ruesch M, Gratwohl A, Irsch J, Lin L, Buser A. Pathogen-inactivation of platelet components with the INTERCEPT Blood System: a cohort study. *Transfus Apher Sci* 2011;45(2):175-181.
41. Snyder E, Raife T, Lin L, Cimino G, Metzger P, Rheinschmidt M, Baril L, Davis K, Buchholz DH, Corash L, Conlan MG. Recovery and Lifespan of 111 Indium radiolabeled platelets treated with pathogen inactivation using amotosalen HCl (S-59) and UVA light. *Transfusion* 2004; 44:1732-1440.
42. Corash, L, Paton V, et al. S-59 clearance and kinetics after transfusion of platelets treated with Helinx™ Technology. *Transfusion* 2000;40(S10):137.
43. Slichter SJ, Raife TJ, Davis K, Rheinschmidt M, Buchholz DH, Corash L, Conlan MG. Platelets photochemically treated with amotosalen HCl and ultraviolet A light correct prolonged bleeding times in thrombocytopenic patients. *Transfusion* 2006;46:731-740.
44. Osselaer JC, Doyen C, Defoin L, Debry C, Goffaux M, Messe N, Van Hooydonk M, Bosly A, Lin JS, Lin L, Corash L. Universal adoption of pathogen inactivation of platelet components: impact on platelet and red blood cell component use. *Transfusion* 2009;49(7):1412-1422.
45. Cazenave JP, Isola H, Waller C, Mendel I, Kientz D, Laforêt M, Raidot JP, Kandel G, Wiesel ML, Corash L. Use of additive solutions and pathogen inactivation treatment of platelet components in a regional blood center: impact on patient outcomes and component utilization during a 3-year period. *Transfusion* 2011;51(3):622-629.
46. Cazenave JP, Isola H, et al., Hemovigilance surveillance of therapeutic plasma prepared with pathogen inactivation treatment during a two year period. XIIth International Haemovigilance Seminar, Dubrovnik, Croatia, 2010.
47. Osselaer JC, Cazenave JP, Lambermont M, Garraud O, Hidajat M, Barbolla L, Tardivel R, Defoin L, Waller C, Mendel I, Raidot JP, Kandel G, De Meuter R, Fabrigli P, Dehenau D, Arroyo JL, Padrón F, Gouezec H, Corral M, Jacquet M, Sundin D, Lin L, Corash L. An active haemovigilance programme characterizing the safety profile of 7437 platelet transfusions prepared with amotosalen photochemical treatment. *Vox Sang* 2008;94(4):315-323.
48. Osselaer JC, Messe N, Hervig T, Bueno J, Castro E, Espinosa A, Accorsi P, Junge K, Jacquet M, Flament J, Corash L. A prospective observational cohort safety study of 5106 platelet transfusions with components prepared with photochemical pathogen inactivation treatment. *Transfusion* 2008;48(6): 1061-1071.
49. Andreu G, Morel P, Forestier F, Debeir J, Rebibo D, Janvier G, Hervé P. Hemovigilance network in France: organization and analysis of immediate transfusion incident reports from 1994 to 1998. *Transfusion* 2002;42(10):1356-1364.
50. Sweeney J, Lozano M. Platelet Transfusion Therapy. Bethesda: AABB Press, 2013.
51. Swissmedic Haemovigilance Annual Report, 2010.
52. Swissmedic Haemovigilance Annual Report, 2011.
53. Swissmedic Haemovigilance Annual Report, 2012.
54. Swissmedic, Haemovigilance Annual Report. 2013.
55. Swissmedic, Haemovigilance Annual Report. 2014.
56. Swissmedic, Haemovigilance Annual Report. 2015.
57. Swissmedic 2016-2020: <https://www.swissmedic.ch/swissmedic/en/home/humanarzneimittel/market-surveillance/haemovigilance/haemovigilance-publications-events.html>
58. ANSM archive, 2001-2019: [https://archiveansm.integra.fr/afssaps/Mediatheque/Publications/Bilans-Rapports-d-activite-Bilans-et-rapports-d-activite#folder\\_26762](https://archiveansm.integra.fr/afssaps/Mediatheque/Publications/Bilans-Rapports-d-activite-Bilans-et-rapports-d-activite#folder_26762)
59. ANSM 2020: <https://ansm.sante.fr/actualites/rapport-dactivite-hemovigilance-2020-des-conclusions-rassurantes>.
60. Infanti, LA, A Holbro, et al., Clinical impact of amotosalen-ultraviolet A pathogen-inactivated platelets stored for up to 7 days. *Transfusion*, 2019. 59(11): p. 3350-61

61. Boudjedir K, Lenzotti A-M, Drougard S, Fromage M, Matko C, Sandid I, Sainte-Marie I. Inactivation des pathogènes par le procédé Intercept® dans les concentrés plaquettaires : bilan de 3 ans de généralisation en France. *Transfusion Clinique et Biologique* 2021;28: S7

InterSol is trademark of Fenwal, Inc.  
SSP+ is trademark of Maco Pharma.

**Manufactured for:**  
Cerus Corporation  
1220 Concord Avenue  
Concord, CA 94520 USA  
Cerus and INTERCEPT are trademarks of Cerus Corporation.